

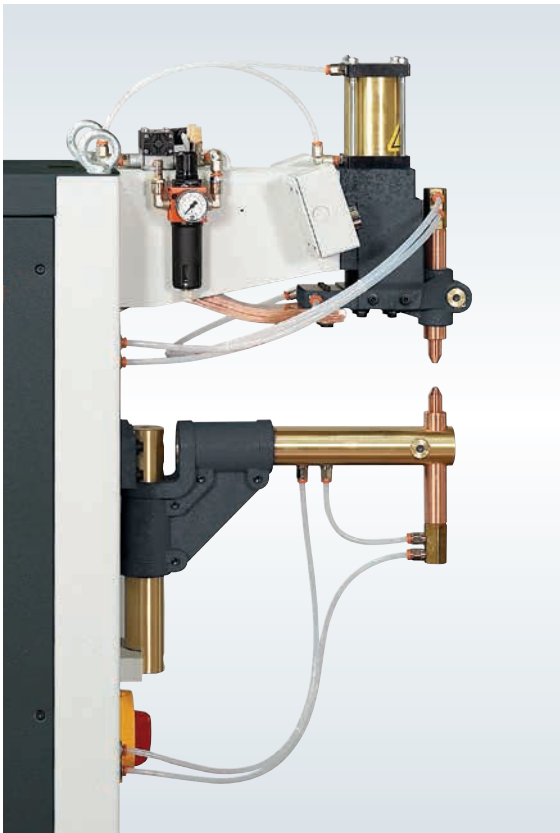

VERTICAL STROKE SPOT AND PROJECTION WELDERS

Being suitable for both spot and projection welding jobs, PPN models fully satisfy an extremely large variety of the heaviest mass production industrial applications. Equipped with a microprocessor control and safety concomitant side buttons, upon request they can also be supplied fitted with special controls and in different configurations.



- Excellent welding on all weldable metals
- Synchronous ignition SCR group with phase shift welding current adjustment to eliminate initial transient
- Thermostatic protection on the SCR group
- High welding currents with low consumption
- Set up time reduction thanks to quick and easy modification of electrodeholders platens opening without any intervention on the secondary circuit (patent pending)
- Self-lubricated pneumatic components to eliminate oil deposits and to safeguard the environment from contaminants
- Water cooled secondary circuit, i.e. electrodes, electrodeholders, platens and transformer, to avoid overheating
- Water cooled copper electrodeholders with adjustable height
- Electrode force adjustable by pressure reducer group equipped with a manometer and filter for automatic air impurity expulsion
- Upper electrode movement by self-lubricated double effect pneumatic cylinder fitted with speed regulator, end stroke shock-absorber and silencer for compressed air discharge
- Solenoid valve to control welding cylinder
- Safety cycle start by means of concomitant side buttons or, alternatively only if the operator can work in safe conditions, by electric pedal. Either option can be chosen by a selector with removable key
- Cycle stop emergency button

PPN 63

THEY ARE EQUIPPED WITH:

- ▶ Lower round arm with adjustable height and lateral adjustment
- ▶ Electrodeholders with electrodes for spotwelding and ability to easily fit barholders for projection welding
- ▶ Lower arm holder can be adjusted for use with larger arm gap
- ▶ Spotwelding (A)
- ▶ Projection welding with bars for mesh (B)

UPON REQUEST ALSO AVAILABLE WITH:

- ▶ Different length arms (optional)
- ▶ Lower arms with pressed-in electrode (for entering pipes or boxes) and longer electrodeholder on the upper arm (optional)
- ▶ Special version with platens only for projection welding (PPN 63) (C)

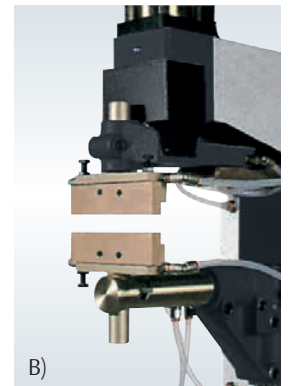
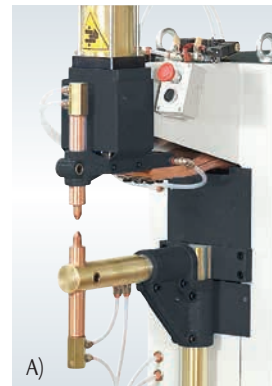

PPN 83 - 103 - 153 - 253

All supplied with lower platen adjustable in height and fitted with T-slots, enabling the quick assembly of barholders, electrodeholders or any dedicated tooling for a specific application. Platens gap is easily and quickly adjustable without any intervention on the secondary circuit (patent pending).

- ▶ Manual valve for upper head descent without pressure for cleaning, centering and ordinary maintenance of the electrodes
- ▶ Upper head low friction driving system for precision welding (except PPN 83)

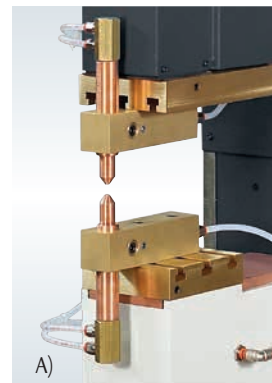

- A) Spotwelding
- B) Barholder welding for mesh
- C) Projection welding



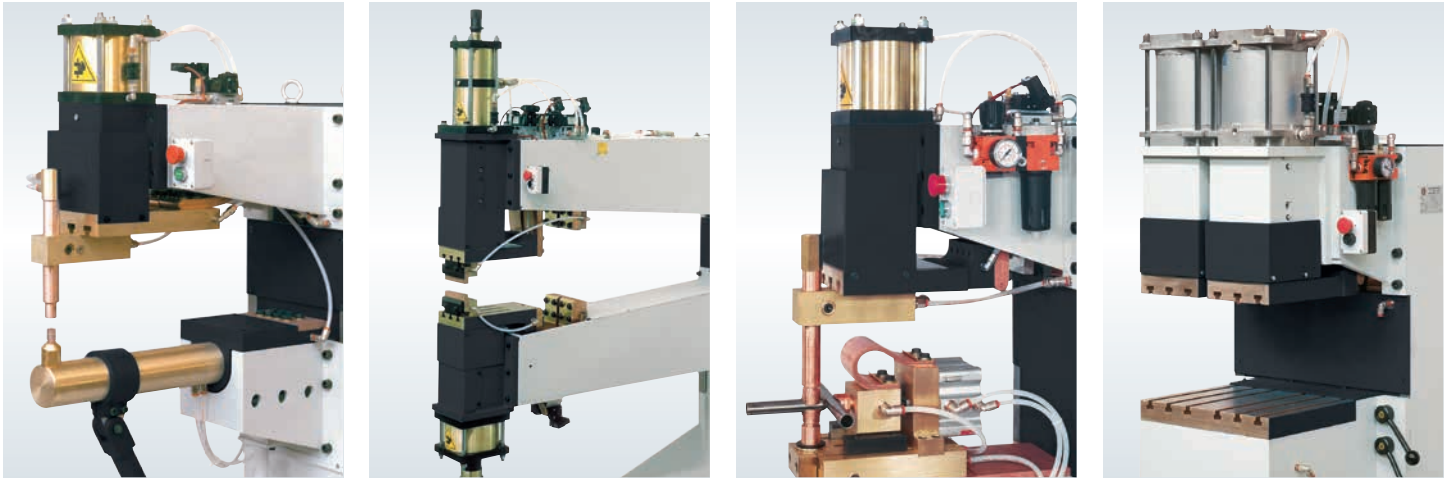

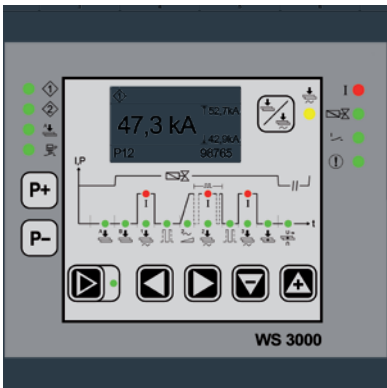
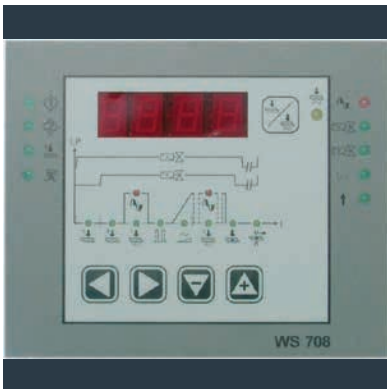

CUSTOMIZED VERSIONS

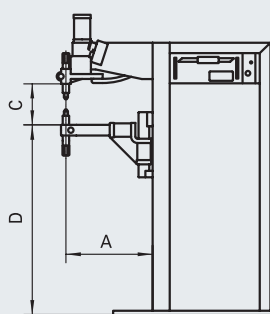

ELECTRONIC CONTROLS

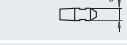
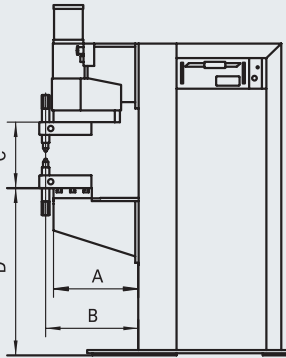
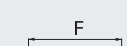

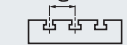
FUNCTIONS	WS 708	WS 3000 AC	FILIUS MULTI
Pre-squeeze time	●	●	
Squeeze time	●	●	●
Preheating time	●	●	●
Preheating current	●	●	●
Cooling time	●	●	●
Slope up	●	●	●
Welding time	●	●	●
Welding current	●	●	●
½ period welding time	●	●	●
Welding time 2 (2 pedal version)	●	●	●
Welding current 2 (2 pedal version)	●	●	●
Pulse interval time	●	●	●
Pulse number	●	●	●
Post heating time		●	●
Post heating current		●	●
Holding time	●	●	●
Pause time	●	●	●
Auto-repeat	●	●	●
Program no.	8	100	32
Welding current display		●	●
Limit monitoring		●	●
Constant current			●
Mains voltage compensation	●	●	●
Error message	●	●	●
Spot counter		●	●
Pressure contact	●	●	●
Cycle end contact	●	●	●

PPN 63		PPN		63	83	103	153	253	
	A		mm	435	400	400	400	445	
	A (Optional)	MIN.	mm	650	650	650	650	650	
		MAX.	mm	750	---	---	---	---	
	B		mm	---	445	445	445	490	
	C	MIN.	mm	180	145	145	145	200	
		MAX.	mm	510	300	300	300	330	
	D	MIN.		615	800	800	800	865	
		MAX.		945	955	955	955	995	
				Ø mm	60	---	---	---	---
				Ø mm	35	30	35	35	35
			Ø mm	19	19	25	25	25	
PPN 83 - 103 - 153 - 253 			Ø mm	---	150	180	180	200	
			E mm	---	150	180	180	200	
			F mm	---	150	180	180	200	
			G mm	---	63	63	63	63	
			T	---	2	3	3	3	

TECHNICAL DATA		PPN				
		63	83	103	153	253
Single phase input 50/60 Hz	V	400	400	400	400	400
Rated power at 50%	kVA	60	80	100	150	250
Short circuit power	kVA	142	266	366	575	763
Max. welding power	kVA	113	210	293	460	610
Installed power	kVA	38	65	78	120	195
Cross section connecting cables	mm ²	35	50	50	95	120
Delayed fuse	A	100	150	200	300	500
Open Circuit Voltage	V	5,9	8,3	9,4	11,5	12,5
Short circuit current	kA	24	32	39	50	61
Max. welding current	kA	19	25	31,2	40	49
Thermal secondary current at 100%	kA	7,2	6,8	7,5	10,1	14,2
Work stroke	mm	65	100	100	100	100
Max. electrode force (6 bar)	daN	470	736	900	1200	1884
Water consumption at 300 kPa (3 bar)	l/min	7	8	8	8	8
Dimensions	↗ mm	1070	1115	1115	1170	1210
	→ mm	430	400	400	400	460
	↑ mm	1520	1650	1650	1800	1800
Weight	kg	335	560	580	610	900

Other voltages on request.

Technical features might change without notice.